

# **Water Specialist 1.5" and 2L Control Valve Service Manual**



## Table of Contents

Installation Summary.....	4
General Specifications and Pre-Installation Checklist.....	5
Installation .....	6
Service Instructions .....	9
Trouble Shooting Procedures.....	13
Warranty.....	16

---

---

## Installation Summary

Installation Date: \_\_\_\_\_

Installation Location: \_\_\_\_\_

Installer(s): \_\_\_\_\_

Phone Number: \_\_\_\_\_

Application Type: (Softener) \_\_\_\_\_ Other: \_\_\_\_\_

**Water Source:** \_\_\_\_\_

### Water Test Results:

Hardness: \_\_\_\_\_ Iron: \_\_\_\_\_ pH: \_\_\_\_\_

Other: \_\_\_\_\_

---

### Misc:

Service Flow Rates: min. \_\_\_\_\_ max. \_\_\_\_\_

Tank Size: Diameter \_\_\_\_\_ Height: \_\_\_\_\_

Resin or Media Volume: \_\_\_\_\_

Resin or Media Type: \_\_\_\_\_

Capacity: \_\_\_\_\_

Salt or Fill Setting per Regeneration: \_\_\_\_\_

Brine Tank Size: \_\_\_\_\_

### Control Valve Configuration:

Valve Type: \_\_\_\_\_

Valve Part Number: \_\_\_\_\_

Valve Serial Number: \_\_\_\_\_

Regenerant Refill Control: \_\_\_\_\_ gpm/lpm

Injector Size: \_\_\_\_\_

Drain Line Flow Control: \_\_\_\_\_ gpm/lpm

**Table 1**  
**General Specifications and Pre-Installation Checklist**

Minimum/Maximum Operating Pressures	20 psi (138 kPa) -125 psi (862 kPa)
Minimum/Maximum Operating Temperatures	40°F (4°C) - 110°F (43°C)
AC Adapter:	<u>U.S.</u> <u>International</u>
Supply Voltage	120 V AC              230V AC
Supply Frequency	60 Hz                  50 Hz
Output Voltage	12 V AC                12 V AC
Output Current	500 mA                500 mA
No user serviceable parts are on the PC board, the motor, or the AC adapter. The means of disconnection from the main power supply is by unplugging the AC adapter from the wall.	
Service flow rate	1.5" Valve: 60 gpm (227 lpm) @ 15 psig (103 kPa) drop 2L Valve: 75 gpm (284 lpm) @ 15 psig (103 kPa) drop
Backwash flow rate	50 gpm (189 lpm) @ 25 psig (172 kPa) drop
CV Service	1.5" Valve: 15.5 2L Valve: 19.4
CV Backwash	10.0
Meter:	
Accuracy	± 5%
Flow Range	1.5" Valve: 0.5 – 60 gpm (1.9 – 227 lpm) 2L Valve: 1.5 – 150 gpm (5.7 – 568 lpm)
Regenerant Refill Rate	0.5 gpm (1.9 lpm)
Injectors	See Injector Graphs
Inlet / Outlet	1.5" Valve: 1.5" NPT or BSPT 2L Valve: 2" NPT or BSPT
Drain Line	1.25" NPT
Distributor Tube Opening	
Valve bodies with female NPT Inlet & Outlet	1.90" OD (1.5" NPS)
Valve bodies with female BSPT Inlet & Outlet	50 mm OD
Tank Connection	1.5" Valve: 4" – 8 UN 2L Valve: 4" – 8 UN 2L Valve Quick Connect: 4" – 8 UN or 6" Flange
Shipping Weight	1.5" Valve and Meter: 21 lbs (10 kg) 2L Valve and Meter: 29 lbs (13 kg) 2L Valve Quick Connect: 30 lbs (14 kg) 4" – 8 UN Tank Connection: 2.5 lbs (1 kg) 6" Flange Tank Connection: 7 lbs (3 kg)
PC Board Memory	Nonvolatile EEPROM (electrically erasable programmable read only memory)
Compatible with the following typical concentrations of regenerants/chemicals	Sodium chloride, potassium chloride, potassium permanganate, sodium bisulfite, chlorine and chloramines

## Installation

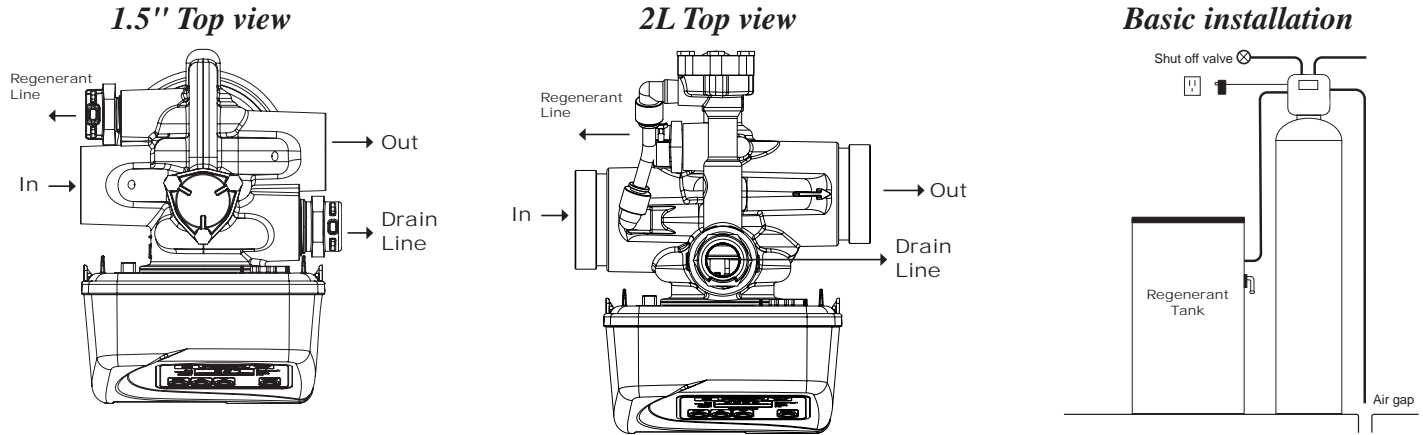

### GENERAL INSTALLATION & SERVICE WARNINGS

The control valve and fittings are not designed to support the weight of the system or the plumbing.

Do not use Vaseline, oils, other hydrocarbon lubricants or spray silicone anywhere. A silicone lubricant may be used on black o-rings but is not necessary. Avoid any type of lubricants, including silicone, on clear lip seals.

**THIS WATER METER SHOULD NOT BE USED AS THE PRIMARY MONITORING DEVICE FOR CRITICAL HEALTH EFFECT APPLICATIONS**

Do not use pipe dope or other sealants on threads. Teflon tape is recommended to be used on all threads. Use of pipe dope may break down the plastics in the control valve.

### SITE REQUIREMENTS:

- The plug-in AC adapter is for dry locations only
- The tanks should be on a firm, level surface
- Electrical: Use an uninterrupted outlet installed within 15 feet (4.57 meters) of the water conditioner.

All plumbing should be done in accordance with local codes.

1. Locate the water conditioner so the distance between the drain and the water conditioner is as short as possible.
2. Regenerant tanks that must be refilled should be located where they are easily accessible. It is recommended a safety brine valve be used.
3. Do not install any water conditioner with less than 10 feet of piping between its outlet and the inlet of a water heater.
4. Do not locate unit where it or its connections (including the drain and overflow lines) will ever be subjected to room temperatures under 40° F (4° C).
5. The use of resin cleaners in an unvented enclosure is not recommended.

6. **INLET/OUTLET PLUMBING:** Connect to a supply line downstream of outdoor spigots. Install an inlet shutoff valve and plumb to the unit's inlet located at the left front as you face the unit. Installation of a bypass valve is recommended. If using plastic fittings ground the water conditioner per local electric codes. If a water meter is used, install the water meter parallel to the floor on the outlet side of the control valve. The turbine assembly may be orientated in any direction, but is usually orientated pointing up to reduce drainage out of the pipes during service. Remove the cover and drive bracket and thread the water meter cord through the hole in the back plate. Reinstall the drive bracket. Weave the cord through the hooks on the right hand side of the drive bracket and connect the end to the three prong connector labeled **METER** on the printed circuit board. Replace the cover.

7. Drain: Verify that the drain can handle the backwash rate of the water conditioner. Correctly size the drain line and install an appropriately sized drain line flow control. An adapter fitting is supplied with a valve that can connect to a 3/4" fitting that can be used with drain line flow controls up to 10 gpm, or an optional 1" fitting that can be used with drain line flow controls up to 25 gpm. If necessary the adapter can be removed and the 1 1/4" threaded drain outlet may be used. Solder joints near the drain must be done prior to connecting the drain line flow control fitting. Leave at least 6" (152.4 mm) between the drain line flow control fitting and solder joints to prevent heat from damaging the flow control. Avoid elevating the drain line above the control valve where possible. Discharge the drain line through an air gap to a receptacle in accordance with local plumbing codes.

**IMPORTANT: Never insert a drain line directly into a drain, sewer line, or trap. Always allow an air gap between the drain line and the receptacle to prevent back siphonage.**

8. Regeneration: If the control valve is to be used to regenerate the water conditioner with brine (saturated salt solution) or other regenerants, use a polyethylene tube to connect the brine valve contained in the regenerant tank to the regenerant port on the control valve. It is recommended the brine valve contain a safety float. The control valve regenerant port has a 1/2" fitting. Note that 1/2" tube runs longer than 6 feet may restrict draw rates with G and H injectors. A 5/8" fitting is also available. See the Refill Flow Control Assembly diagram in the Programming and Drawings Manual for injector part numbers. See Table 2 for injector color codings, and the injector graphs at the end of this manual for total, slow rinse and draw flow rates.

**Table 2  
Injector Order Information**

Injector Order Number	Injector Color	Typical Tank Diameter <sup>1</sup>
V3010-15B	Violet	12"
V3010-15C	Red	13"
V3010-15D	White	14"
V3010-15E	Blue	16"
V3010-15F	Yellow	18"
V3010-15G	Green	21"
V3010-15H	Orange	24"

An overflow drain line from the regenerant tank that discharges into an acceptable drain is recommended, as a regenerant overflow could damage furnishings or the building structure. Connect a line to the overflow fitting on the regenerant tank. If an overflow fitting is not already installed on the regenerant tank, install one. Do not elevate the overflow drain line. Discharge the overflow drain line through an air gap to a receptacle in accordance with local plumbing codes.

9. AC Adapter: If an AC Adapter is already connected to the control valve, plug the AC Adapter into an uninterrupted outlet. If the AC Adapter cord has not yet been connected to the control valve, remove the control valve cover and the drive bracket and thread AC Adapter cord through the hole in the back plate. Reinstall the drive bracket. Weave the cord through the hooks on the right hand side of the drive bracket and connect the end to the four prong connector labeled 12VAC PWR on the printed circuit board. Replace the cover. Plug the AC Adapter into an uninterrupted outlet.

10. Program the control valve: It is very important to program the control valve for the type of system (e.g. water softener or filter) and the end use application. Check the program used prior to testing the system.

Systems with a Regenerant Tank

- After installation is completed, check for leaks.
- Fully open a cold water faucet down stream of the system.
- Allow water to run until clear.
- Close the cold water faucet and water supply valve.
- The system is now ready for testing:

<sup>1</sup> Actual injector size used may vary depending on the design and application of the system. The injectors in Table 2 are sized for a typical downflow softener using standard mesh synthetic cation exchange media regenerating with sodium chloride.

1. Manually pour enough water into the regenerant tank to reach the top of the air check valve.
2. Press and hold the REGEN button for three seconds until the drive motor starts. Wait until the motor stops and the display reads "Backwash." The backwash time will begin to count down.
3. Open the inlet water supply valve very slowly allowing water to fill the tank in order to expel air. CAUTION: If water flows too rapidly, there will be a loss of media out of the drain.
4. When the water is flowing steadily to the drain without the presence of air, press the REGEN button to advance the control to the brine position. The brine time will begin to count down.
5. Fully open the water supply inlet valve.
  - Check to verify that water is being drawn from the regenerant tank
  - There should be a slow flow to the drain
  - Allow three minutes for the media bed to settle
6. Press the REGEN button again to advance to the next position and allow water to run to drain for 2-3 minutes. The display will read "backwash" or "rinse" depending on the program used. If "backwash" is displayed, press the REGEN button to advance the control to the rinse position. Allow water to run to drain until clear.
7. Press the REGEN button to advance to the next position. The display should read "fill". Allow water to run into the regenerant tank and prepare it for the next regeneration. Allow the regenerant tank to fill automatically.
8. While the regenerant tank is filling, load it with regenerant.
9. SANITIZE! Add a sanitizer to the regenerant tank brine well following dosage recommendations specified by the media manufacturer. Press and hold the REGEN button for three seconds to begin regeneration. Allow the system to complete the regeneration automatically. The system will now be sanitized and producing treated water. Be sure to check for local codes, which may also specify sanitization methods.

#### Systems without a Regenerant Tank

- After installation is completed, check for leaks.
- Fully open a cold water faucet down stream of the system.
- Allow water to run until clear.
- Close the cold water faucet and water supply valve.
- The system is now ready for testing:
  1. Press and hold the REGEN button for three seconds until the drive motor starts. Wait until the motor stops and the display reads "Backwash." The backwash time will begin to count down.
  2. Open the inlet water supply valve very slowly allowing water to fill the tank in order to expel air. CAUTION: If water flows too rapidly, there will be a loss of media out of the drain.
  3. When the water is flowing steadily to the drain without the presence of air, fully open the water supply inlet valve.
  4. Press the REGEN button again to advance to the next position and allow water to run to drain for 2-3 minutes. The display will read "backwash" or "rinse" depending on the program used. If "backwash" is displayed, press the REGEN button to advance to the rinse position. Allow water to run to drain until clear.
  5. Press the REGEN button to advance to the service position.
  6. SANITIZE! Add a sanitizer to the media following dosage recommendations specified by the media manufacturer. Be sure to check for local codes, which may also specify sanitization methods.

## Service Instructions

### Drive Assembly

Remove the valve cover to access the drive assembly.

Disconnect the power source plug (black wire) from the PC board prior to disconnecting the motor or water meter plugs from the PC board. The motor plug connects to the two-pin jack on the left-hand side of the PC board. The power source plug connects to the four-pin jack. The water meter plug (gray wire) connects to the three-pin jack on the far right-hand side of the PC board.

The PC board can be removed separately from the drive bracket but it is not recommended. Do not attempt to remove the display panel from the PC board. Handle the board by the edges. To remove the PC board from the drive bracket, unplug the power, water meter and motor plugs from the PC board. Lift the middle latch along the top of the drive bracket while pulling outward on the top of the PC board. The drive bracket has two plastic pins that fit into the holes on the lower edge of the PC board. Once the PC board is tilted about 45° from the drive bracket it can be lifted off of these pins. To reinstall the PC board, position the lower edge of the PC board so that the holes in the PC board line up with the plastic pins. Push the top of the PC board towards the valve until it snaps under the middle latch, weave the power and water meter wires into the holders and reconnect the motor, water meter and power plugs.

The drive bracket must be removed to access the drive cap assembly and pistons or the drive gear cover. It is not necessary to remove the PC board from the drive bracket to remove the drive bracket. To remove the drive bracket start by removing the plugs for the power source and the water meter. Unweave the wires from the side holders. Two tabs on the top of the drive back plate hold the drive bracket in place. Simultaneously lift the two tabs and gently ease the top of the drive bracket towards your body. The lower edge of the drive bracket has two notches that rest on the drive back plate. Lift up and outward on the drive bracket to disengage the notches.

To reassemble seat the bottom of the drive bracket so the notches are engaged at the bottom of the drive back plate. Push the top of the drive bracket towards the two latches. The drive bracket may have to be lifted slightly to let the threaded piston rod pass through the hole in the drive bracket. Maintain a slight engaging force on top of the drive bracket while deflecting the bracket slightly to the left by pressing on the side of the upper right corner. This helps the drive gears mesh with the drive cap assembly. The drive bracket is properly seated when it snaps under the latches on the drive back plate. If resistance is felt before latching, then notches are not fully engaged, the piston rod is not in hole, the wires are jammed between the drive bracket and drive back plate, or the gear is not engaging the drive cap assembly.

To inspect drive gears, the drive gear cover needs to be removed. Before trying to remove the gear cover, the drive bracket must be removed from the drive back plate. (Refer to the instructions above regarding removing the drive bracket from the drive back plate. The drive gear cover can be removed from the drive bracket without removing the motor or the PC board.) The drive gear cover is held in place on the drive bracket by three clips. The largest of the three clips is always orientated to the bottom of the drive bracket. With the PC board facing up, push in and down on the large clip on the drive gear cover. Handle the cover and the gears carefully so that the gears do not fall off of the pegs in the cover.

Replace broken or damaged drive gears. Do not lubricate any of the gears. Avoid getting any foreign matter on the reflective coating because dirt or oils may interfere with pulse counting.

The drive gear cover only fits on one way, with the large clip orientated towards the bottom. If all three clips are outside of the gear shroud on the drive bracket the drive gear cover slips easily into place.

The drive bracket does not need to be removed from the drive plate if the motor needs to be removed. To remove the motor, disconnect the power and motor plugs from the jacks on the PC board. Move the spring clip loop to the right and hold. Rotate the motor at least a ¼ turn in either direction before gently pulling on the wire connectors to remove the motor. Pulling directly on the wires without rotating the motor may break the wires off the motor.

Replace the motor if necessary. Do not lubricate the motor or the gears. To reinstall the motor, move the spring clip loop to the right and hold. Gently turn the motor while inserting so that the gear on the motor meshes with the gears under the drive gear cover. Release the spring clip loop and continue to rotate the motor until the motor housing engages the small plastic bulge inside the drive bracket motor retainer. Reconnect the motor plug to the two-pronged jack on the lower left hand side of the PC board. If the motor will not easily engage with the drive gear when reinstalling, lift and slightly rotate the motor before reinserting. Reconnect the power plug.

Replace the valve cover. After completing any valve maintenance, press and hold NEXT and REGEN buttons for 3 seconds or unplug power source jack (black wire) and plug back in. This resets the electronics and establishes the service piston position. The display should flash all wording, then flash the software version and then reset the valve to the service position.

#### Drive Cap Assembly, Main Piston and Regenerant Piston

The drive assembly must be removed to access the drive cap assembly. The drive cap assembly must be removed to access the piston(s). The drive cap assembly is threaded into the control valve body and seals with an o-ring. To remove the drive cap assembly use the special plastic wrench (V3193-01 Figure 1) or insert a ¼" to ½" flat bladed screwdriver into one of the slots around the top 2" of the drive cap assembly so it engages the notches molded into the drive back plate around the top 2" of the piston cavity. See Figure 2. The notches are visible through the holes. Lever the screwdriver so the drive cap assembly turns counter clockwise. Once loosened unscrew the drive cap assembly by hand and pull straight out.

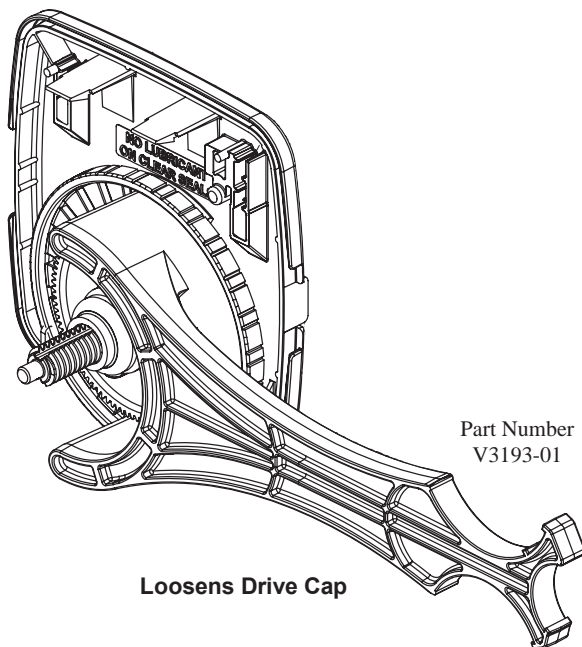

**Figure: 1**

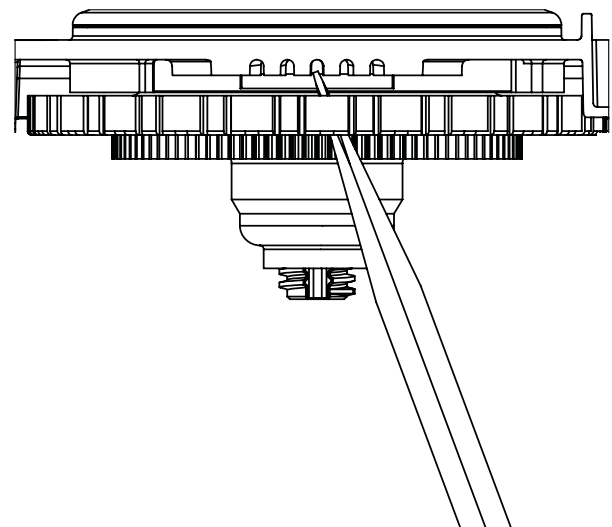

**Figure: 2**

The drive cap assembly contains the drive cap, the main drive gear, drive cap spline, piston rod and various other parts that should not be disassembled in the field. The only replaceable part on the drive cap assembly is the o-ring. Attached to the drive cap assembly is the main piston (down flow) and if a regenerant is used, a regenerant piston.

The regenerant piston (the small diameter one behind the main piston) is removed from the main piston by unsnapping it from its latch. Chemically clean in dilute sodium bisulfite or vinegar or replace the regenerant piston if needed. To remove the main down flow piston fully extend the piston rod and then unsnap the main piston from its latch by pressing on the side with the number. Chemically clean in dilute sodium bisulfite or vinegar, or replace the main piston. The main piston is teflon coated. If the teflon coating is abraded, replace the main piston.

Reattach the main piston to the drive cap assembly. Reattach the regenerant piston (if needed) to the main piston. Do not lubricate the piston rod, main piston or regenerant piston. Lubricant will adversely affect the clear lip seals. Reinsert the drive cap assembly and piston into the spacer stack assembly and hand tighten the drive cap assembly. Continue to tighten the drive cap assembly using a screwdriver as a ratchet or the V3193-01 wrench until the black o-ring on the spacer stack assembly is no longer visible through the drain port. Excessive force can break the notches molded into the drive back plate. Make certain that the main drive gear still turns freely. The exact position of the piston is not important as long as the main drive gear turns freely.

Reattach the drive assembly to the control valve and connect all plugs. After completing any valve maintenance, press and hold NEXT and REGEN buttons for 3 seconds or unplug power source jack (black wire) and plug back in. This resets the electronics and establishes the service piston position. The display should flash all wording, then flash the software version and then reset the valve to the service position.

### Spacer Stack Assembly

To access the spacer stack assembly remove the drive assembly, drive cap assembly and piston. The spacer stack assembly can be removed easily without tools by using thumb and forefinger. Inspect the black o-rings and clear lip seals for wear or damage. Replace the entire stack if necessary. The spacer stack assembly has been 100% tested at the factory to insure proper orientation of one way seals. Do not disassemble the stack.

The spacer stack assembly may be chemically cleaned (dilute sodium bisulfite or vinegar) or wiped with a soft cloth.

The spacer stack assembly can be pushed into the control valve body bore by hand. Since the spacer stack assembly can be compressed it is easier to use a blunt object (5/8" to 1-1/8" in diameter) to push the center of the assembly into the control valve body. The assembly is properly seated when at least four threads are exposed (approximately 5/8"). Do not force the spacer stack assembly in. The control valve body bore interior can be lubricated with silicone to allow for easy insertion of the entire stack. Do not use silicone or any other type of lubricant on the clear lip seals or the piston.

Reattach the drive cap assembly and piston(s) and the drive assembly.

After completing any valve maintenance, press and hold NEXT and REGEN buttons for 3 seconds or unplug power source jack (black wire) and plug back in. This resets the electronics and establishes the service piston position. The display should flash all wording, then flash the software version and then reset the valve to the service position.

### Injector Cap, Screen, Injector Plug and Injector

Remove the three bolts from the injector cap and lift off. Remove the screen and clean if fouled.

The injector can be pried out with a small screwdriver. The injector consists of a throat and a nozzle. Chemically clean the injector with vinegar or sodium bisulfite. The holes can be blown out with air. Both pieces have small diameter holes that control the flow rates of water to insure that the proper concentration of regenerant is used. Sharp objects, which can score the plastic, should not be used to clean the injector. Scoring the injector or increasing the diameter of the hole could change the operating parameters of the injector.

If a valve does not use a regenerant the injector plug should not need to be cleaned.

### Refill Flow Control Assembly or Refill Port Plug

To clean or replace the refill flow control, pull out the locking clip and then pull straight out on the fitting. Replace the locking clip in the slot so that it is not misplaced. Twist to remove the white flow control retainer. The flow control can be removed by prying upward through the side slots of the retainer with a small blade flat screwdriver.

Chemically clean the flow control or the white flow control retainer using dilute sodium bisulfite or vinegar. Do not use a wire brush. If necessary, replace the flow control, o-ring on the flow control retainer, or the o-ring on the fitting.

Reseat the flow control so the rounded end is visible in the flow control. Reseat the white flow control retainer by pushing the retainer into the fitting until the o-ring seats. Remove locking clip, push on the fitting to reseat and insert locking clip.

Do not use Vaseline, oils, or other unacceptable lubricants on o-rings. A silicone lubricant may be used on the o-ring on the elbow or the white retainer.

Note: The nut, gripper and retainer sleeve is a three piece assembly that can come apart if removed from the refill flow control fitting. Parts must be reassembled exactly as shown in the refill flow control assembly drawing to function properly. If the nut is completely removed from the body, slip the nut, plastic gripper and gripper sleeve on the tube, then tighten on to the fitting.

Refill port plugs should not need to be serviced. If necessary the locking clip can be removed and the port plug removed to replace the o-ring.

### Water Meter

The water meter assembly is connected to the PC board by a wire. If the entire water meter assembly is to be replaced, remove the control valve cover and remove the power source and water meter plugs from the PC board. Unlatch the drive assembly and lean it forward. Unthread the water meter wire from the side of the drive assembly and through the drive back plate. To reinstall, rethread the water meter wire through the drive back plate and the side of the drive assembly. Reattach the drive assembly and the water meter and power plugs.

The water meter wire does not need to be removed from the PC board if the water meter is only being inspected and cleaned. To remove the water meter assembly, remove the meter clip and using a small screwdriver pry up on the meter assembly.

When the meter is part way out it is easy to remove the water meter from the housing. Once the water meter is removed from the meter body, use your fingers to gently pull forward on the turbine to remove it from the shaft.

Do not use a wire brush to clean. Wipe with a clean cloth or chemically clean in dilute sodium bisulfite or vinegar. The turbine can be immersed in the chemical. Do not immerse electronics. If the turbine is scored or damaged or the bearings on the turbine are worn, replace the turbine.

Do not lubricate the turbine shaft. The turbine shaft bearings are prelubricated. Do not use Vaseline, oils, or other unacceptable lubricants on the o-ring. A silicone lubricant may be used on the black o-ring.

Snap the turbine on the shaft and reinsert the water meter into the meter body. Insert the meter clip.

**Table 3**  
**Troubleshooting Procedures**

Problem	Possible Cause	Solution
1. Timer does not display time of day	a. AC adapter unplugged	a. Connect power
	b. No electric power at outlet	b. Repair outlet or use working outlet
	c. Defective AC adapter	c. Replace AC adapter
	d. Defective PC board	d. Replace PC board
2. Timer does not display the correct time of day	a. Switched outlet	a. Use uninterrupted outlet
	b. Power outage	b. Reset time of day
	c. Defective PC board	c. Replace PC board
3. No softening/filtering display when the water is flowing	a. Bypass valve in bypass position	a. Put bypass valve in service position
	b. Meter connection disconnected	b. Connect meter to PC board
	c. Restricted/stalled meter turbine	c. Remove meter and check for rotation or foreign material
	d. Defective meter	d. Replace meter
	e. Defective PC board	e. Replace PC board
4. Control valve regenerates at wrong time of day	a. Power outages	a. Reset control valve to correct time of day
	b. Time of day not set correctly	b. Reset to correct time of day
	c. Time of regeneration incorrect	c. Reset regeneration time
	d. Control valve set for immediate regeneration	d. Check control valve set-up procedure regeneration time option
5. Error followed by code number  Error Code 1001 - Unable to recognize start of regeneration  Error Code 1002 - Unexpected stall  Error Code 1003 - Motor ran too long, timed out trying to reach next cycle position  Error Code 1004 - Motor ran too long, timed out trying to reach home position  If other Error Codes display contact the factory.	a. Control valve has just been serviced	a. Press NEXT and REGEN for 3 seconds or unplug power source jack (black wire) and plug back in to reset control valve
	b. Foreign matter is lodged in control valve	b. Check piston and spacer stack assembly for foreign matter
	c. High drive forces on piston	c. Replace piston(s) and spacer stack assembly
	d. Control valve piston not in home position	d. Press NEXT and REGEN for 3 seconds or unplug power source jack (black wire) and plug back in to reset control valve
	e. Motor not inserted fully to engage pinion, motor wires broken or disconnected, motor failure	e. Check motor and wiring. Replace motor if necessary
	f. Drive gear label dirty or damaged, missing or broken gear	f. Replace or clean drive gear
	g. Drive bracket incorrectly aligned to back plate	g. Reseat drive bracket properly
	h. PC board is damaged or defective	h. Replace PC board
	i. PC board incorrectly aligned to drive bracket	i. Ensure PC board is correctly snapped on to drive bracket

Problem	Possible Cause	Solution
6. Control valve stalled in regeneration	a. Motor not operating	a. Replace motor
	b. No electric power at outlet	b. Repair outlet or use working outlet
	c. Defective AC adapter	c. Replace AC adapter
	d. Defective PC board	d. Replace PC board
	e. Broken drive gear or drive cap assembly	e. Replace the drive gear or drive cap assembly
	f. Broken piston retainer	f. Replace drive cap assembly
	g. Broken main or regenerant piston	g. Replace main or regenerant piston
7. Control valve does not regenerate automatically when REGEN button is depressed and held	a. AC adapter unplugged	a. Connect AC adapter
	b. No electric power at outlet	b. Repair outlet or use working outlet
	c. Broken drive gear or drive cap assembly	c. Replace drive gear or drive cap assembly
	d. Defective PC board	d. Replace PC board
8. Control valve does not regenerate automatically but does when REGEN button is depressed	a. Bypass valve in bypass position	a. Put bypass valve in normal operation position
	b. Meter connection disconnected	b. Connect meter to PC board
	c. Restricted/stalled meter turbine	c. Remove meter and check for rotation or foreign matter
	d. Defective meter	d. Replace meter
	e. Defective PC board	e. Replace PC board
	f. Set-up error	f. Check control valve set-up procedure
9. Time of day flashes on and off	a. Power has been out more than two hours, AC adapter was unplugged and then plugged back into the wall outlet, the AC adapter plug was unplugged and then plugged back into the board or the NEXT and REGEN buttons were pressed to rest the valve.	a. Reset the time of day

VIOLET, ORDER NO. V3010-15B  
Metric Units

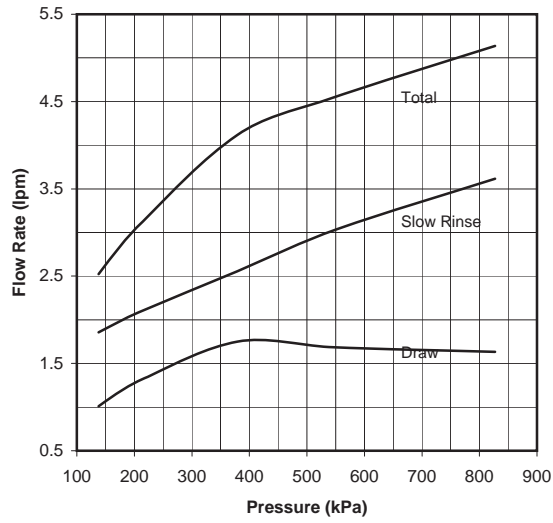

VIOLET, ORDER NO. V3010-15B  
US Units

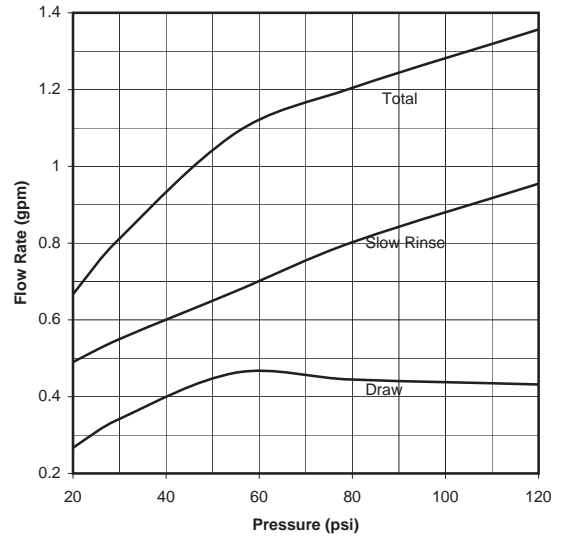

RED, ORDER NO. V3010-15C  
Metric Units

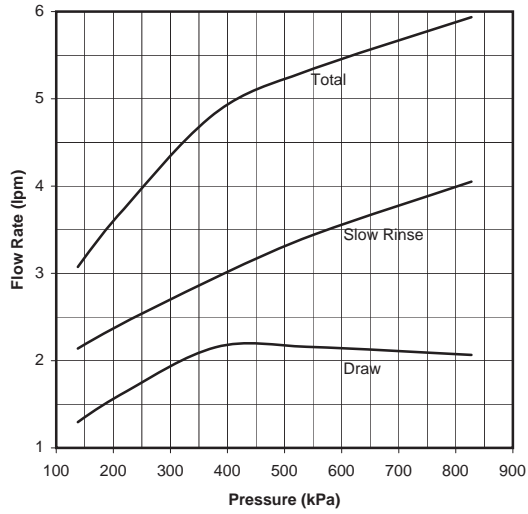

RED, ORDER NO. V3010-15C  
US Units

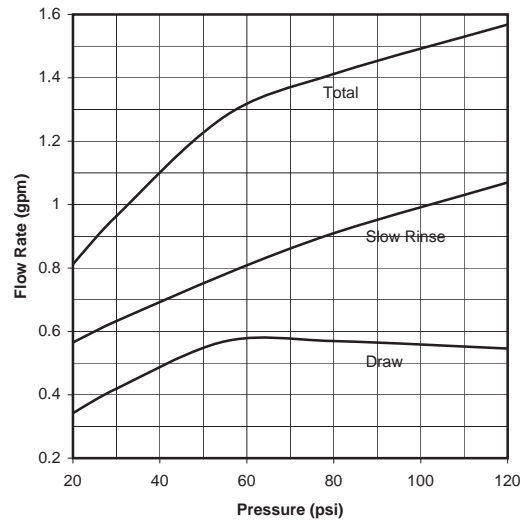

WHITE, ORDER NO. V3010-15D  
Metric Units

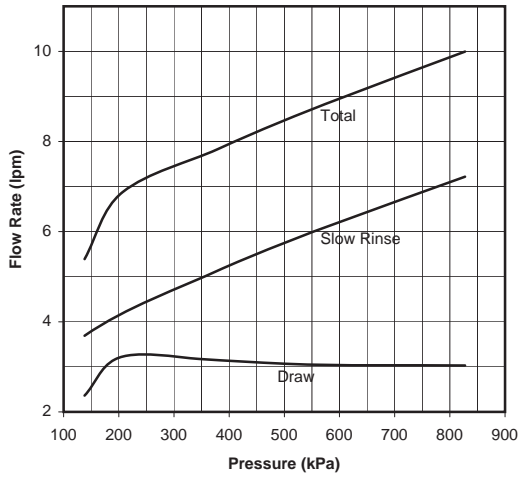

WHITE, ORDER NO. V3010-15D  
US Units

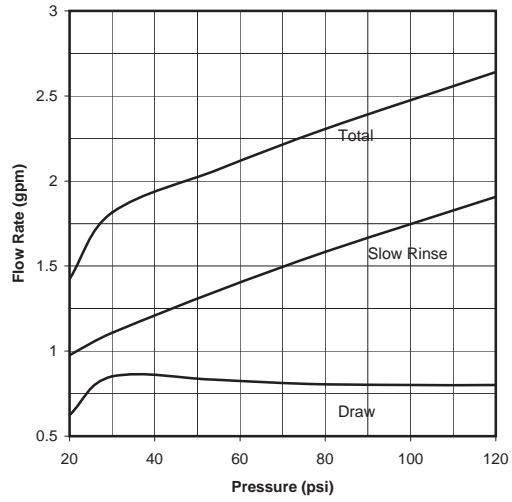

BLUE, ORDER NO. V3010-15E  
Metric Units

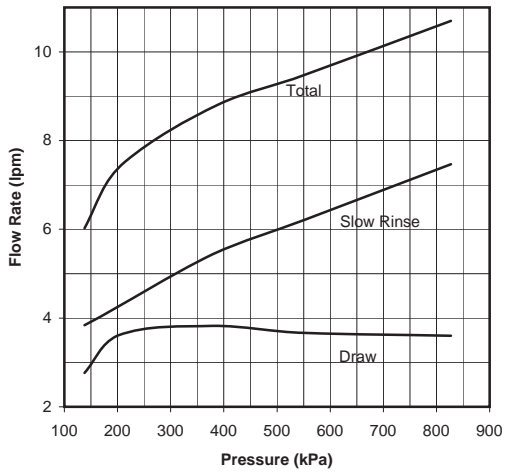

BLUE, ORDER NO. V3010-15E  
US Units

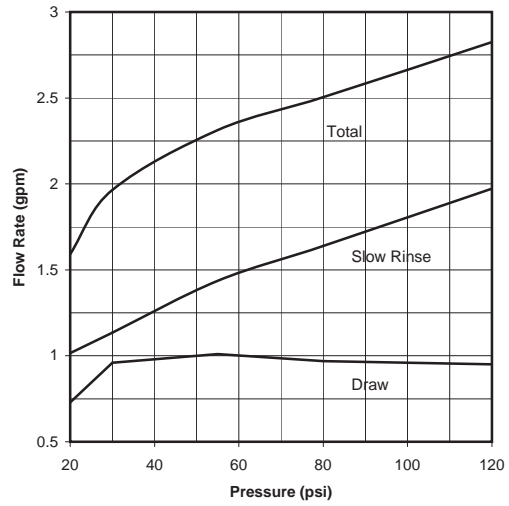

YELLOW, ORDER NO. V3010-15F  
Metric Units

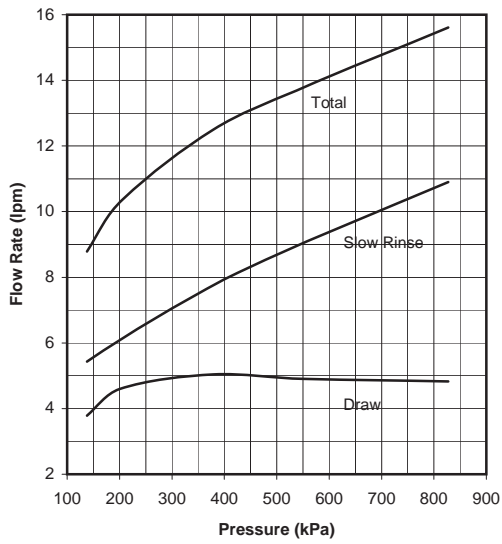

YELLOW, ORDER NO. V3010-15F  
US Units

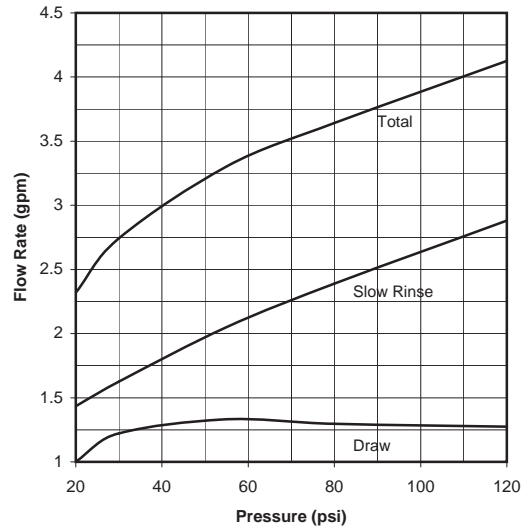

GREEN, ORDER NO. V3010-15G  
Metric Units

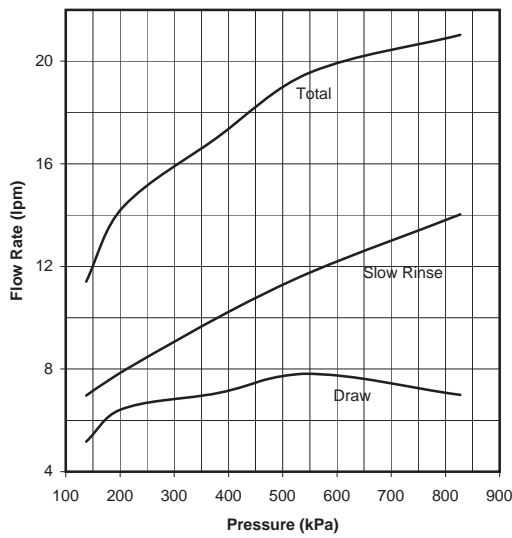

GREEN, ORDER NO. V3010-15G  
US Units

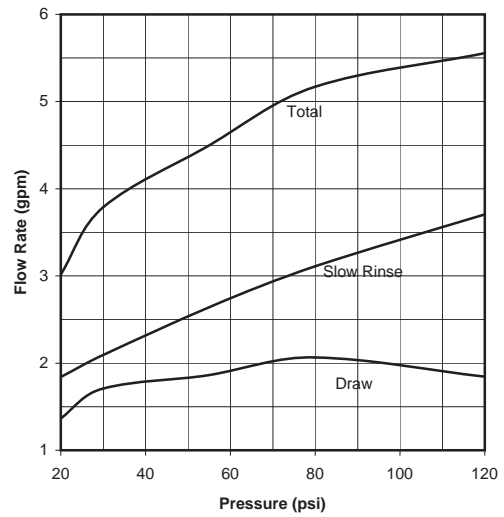

ORANGE, ORDER NO. V3010-15H  
Metric Units

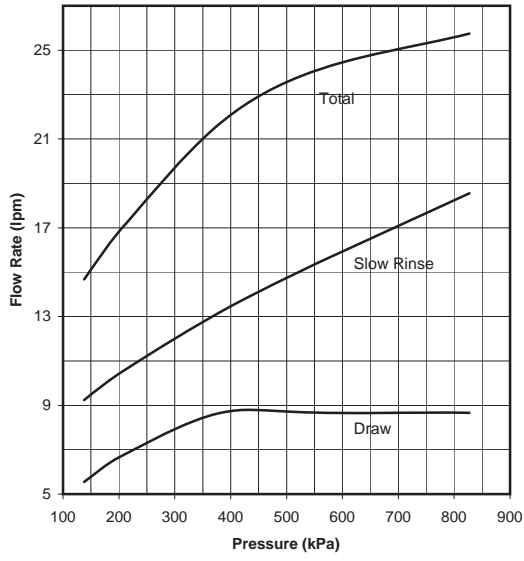

ORANGE, ORDER NO. V3010-15H  
US Units

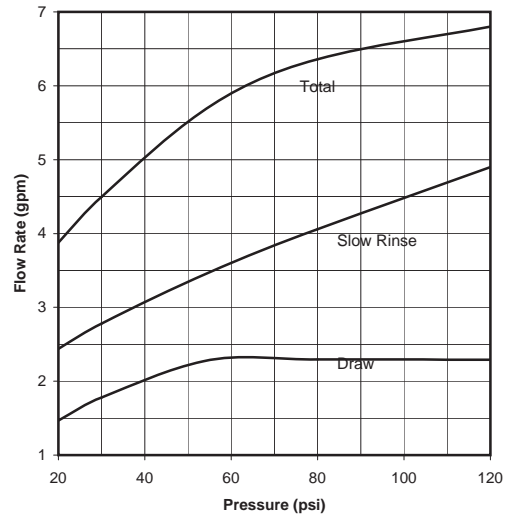



**CLACK CORPORATION**  
**FIVE-YEAR SOFTENER AND FILTER CONTROLS**  
**LIMITED WARRANTY**

Clack Corporation (“Clack”) warrants to OEM that its Softener and Filter Control Valves will be free from defects in material and workmanship under normal use and service for a period of five years from the date of shipment of such Valves from Clack’s plant in Windsor, Wisconsin when installed and operated within recommended parameters. No warranty is made with respect to defects not reported to Clack within the warranty period and/or defects or damages due to neglect, misuse, alterations, accident, misapplication, physical damage, or damage caused by fire, acts of God, freezing or hot water or similar causes. For outdoor installations where the Softener and Filter Control Valves are not under cover, the weather cover must be utilized for the warranty to be valid.

Clack’s obligation to OEM under this Limited Warranty shall be limited, at its option, to replacement or repair of any Softener and Filter Control valve covered by this Limited Warranty. Prior to returning a Control Valve, OEM must obtain a return goods authorization number from Clack and return the Control Valve freight prepaid. If any Control Valve is covered under this Limited Warranty, Clack shall return the Control Valve repaired, or its replacement, prepaid to the original point of shipment.

**CLACK GIVES THIS WARRANTY TO OEM IN LIEU OF ALL OTHER WARRANTIES, EXPRESS OR IMPLIED, INCLUDING WITHOUT LIMITATION ANY IMPLIED WARRANTIES OF MERCHANTABILITY OR FITNESS FOR A PARTICULAR PURPOSE AND HEREBY EXPRESSLY DISCLAIMS ALL OTHER SUCH WARRANTIES. CLACK’S LIABILITY HEREUNDER SHALL NOT EXCEED THE COST OF THE PRODUCT. UNDER NO CIRCUMSTANCES WILL CLACK BE LIABLE FOR ANY INCIDENTAL OR CONSEQUENTIAL DAMAGES OR FOR ANY OTHER LOSS, DAMAGE OR EXPENSE OF ANY KIND, INCLUDING LOSS OF PROFITS, ARISING IN CONNECTION WITH THE INSTALLATION OR USE OR INABILITY TO USE THE CONTROL VALVES OR ANY WATER TREATMENT SYSTEM THE CONTROL VALVE IS INCORPORATED INTO.**