

WS1 Series Microswitch Assembly

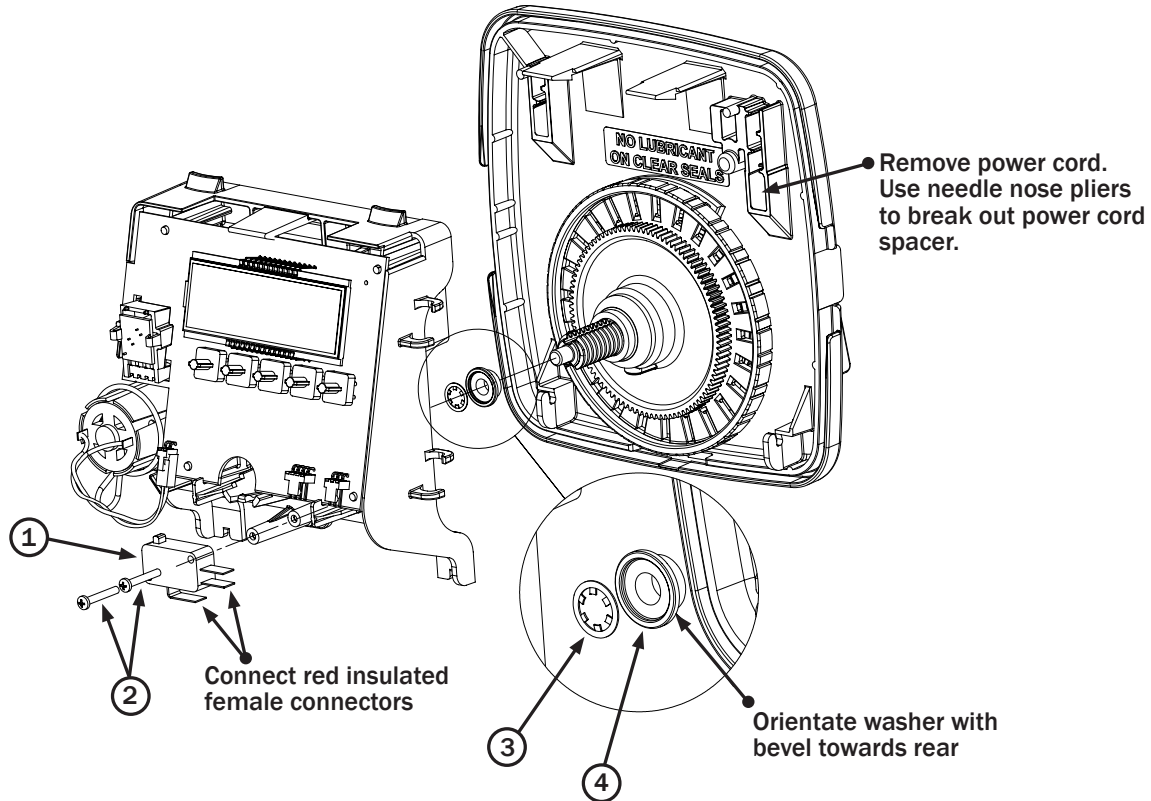

Order No.: V3014

Description: WS1 Series Microswitch Assembly

Drawing No.	Order No.	Description	Quantity
1	V3301	WS1 MICROSWITCH	1
Not Shown	V3340	WS1 INTERCONNECT CORD ASY	1
2	V3304	WS1 SCREWS 4/40 X 3/4	2
3	V3305	WS1 RETAINING RING SS 1/4	1
4	V3335	WS1 WASHER STEPPED	1

The purpose of V3014 is to connect two control valves together so that when one control valve (designated as the primary control valve) is in the refill cycle that a signal is sent to the other control valve (designated as the secondary control valve) to begin its regeneration cycle.

If the system containing the primary control valve is to regenerate before the system containing the secondary control valve then the following must occur:

1. The primary control valve should be programmed so that the refill cycle occurs after the regeneration (i.e. Post fill). The primary control valve must be programmed for at least 6 minutes of refill or 9.5 lbs. of salt.
2. The PC board on the secondary control valve must have a two-pin connection (note the two-pin connector is not available on WS1 and WS1.25). The secondary control valve should be programmed so that the regeneration starts only when the primary control valve is in the refill cycle. This can be accomplished by programming the control valve so that the days between regenerations is long enough to prevent premature regeneration. If the secondary control valve has a meter, make sure that the gallon capacity is programmed to "off". Also program the secondary control valve so that the "dP" switch is set to regenerate immediately.

WS1 Series Microswitch Assembly

To assemble complete the following steps:

1. Review the drawing for the correct stepped washer orientation. On the primary control valve slip the stepped washer and retaining ring on to the end of the piston rod.
2. On the primary control valve attach the microswitch to the drive bracket using the screws.
3. On both the primary and secondary control valves disconnect the power plug from the PC board. Disconnect meter plugs if they are present. Unwind the cords from the side of the bracket. Remove the drive brackets from both the primary and secondary control valves. Thread the power cord back out through the back plate. Using a needle nose pliers break out the power cord spacer on the back plate of both the primary and secondary control valves.
4. On the primary control valve thread the power cord and 9" to 10" of the red insulated female connector end of the interconnect cord through the back plate. On the secondary control valve thread the power cord and 5" to 6" of the Molex plug end of the interconnect cord through the back plate. Weave both cords into the back plate pushing the cords in to firmly seat (if this is not done the drive bracket may not be able to be reinstalled). Reinstall both drive brackets.
5. On the primary control valve weave the power cord, interconnect cord and the meter cord along side the drive bracket. Connect the red terminals from interconnect cord to the two lower terminals (common and normally open) on the microswitch. Reattach the power plug and the meter plug to the PC board.
6. On the secondary control valve connect the interconnect plug to the two pin connection on the PC board. Weave the power cord and the meter cord along side of the drive bracket. Reattach the power plug and the meter plug to the PC board.
7. Test procedure for the assembly: Press and hold the REGEN button on the primary control valve. After the motor stops running press REGEN to step through the cycles until the primary control valve is in the refill cycle. The secondary control valve should begin its regeneration cycle within 2-6 minutes. If the secondary control valve does not begin its regeneration cycle within 2-6 minutes, check the orientation of the stepped washer, the interconnect cord connections and the secondary valve programming.